

**FIRST
LEGO
LEAGUE**

CHALLENGE

ENGINEERING NOTEBOOK

**SUPER
POWERED**





**FIRST® LEGO® League
Global Sponsors**

The **LEGO** Foundation



Challenge Division Sponsors



WELCOME!

Use the sessions in this *Engineering Notebook* as a guide for your team's journey through the *FIRST*® ENERGIZESM season presented by Qualcomm and SUPERPOWEREDSM challenge.

Use the Core Values and the **engineering design process**

throughout your team journey. Have lots of fun as you develop new skills and work together! This notebook is a great resource to share at your judging event, but it isn't required. Check out careers related to the season theme at the end of this notebook.

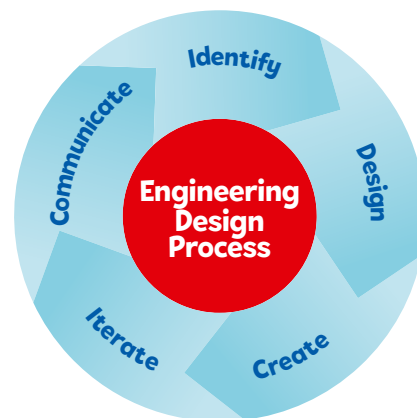

FIRST® Core Values



We are stronger when we work together.



We respect each other and embrace our differences.



We apply what we learn to improve our world.

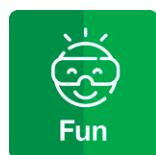

We enjoy and celebrate what we do!

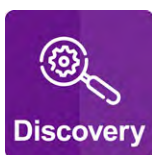

We explore new skills and ideas.



We use creativity and persistence to solve problems.

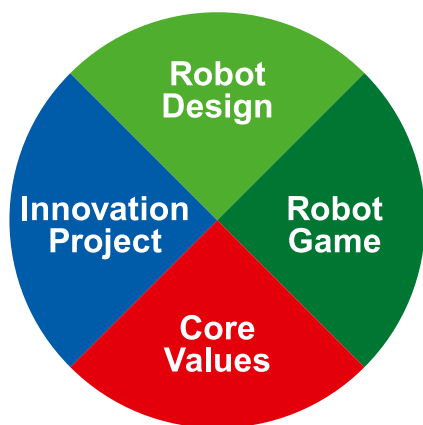

Each of these four equally weighted parts of *FIRST*® LEGO® League Challenge accounts for 25% of your total performance at your event.

Core Values should be demonstrated at the event, where

you will showcase your team's amazing work on Robot Design and the Innovation Project. These three parts will be evaluated during the judging session. Your robot's performance will be evaluated during the Robot Game.

Gracious Professionalism® is a way of doing things that encourages high-quality work, emphasizes the value of others, and respects individuals and the community.

Coopertition® is showing that learning is more important than winning. Teams can help others even as they compete.

We express our Core Values through *Gracious Professionalism*, and this will be evaluated during Robot Game matches.

Team Journey



Design Your Innovation Project



Design Your Robot



Use Engineering Design Process

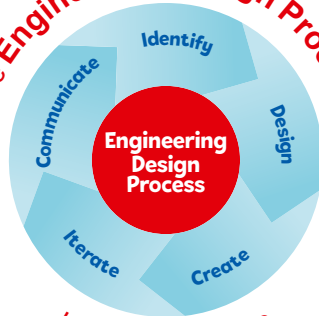

Create your Innovation Project Solution



Create Your Robot Solution



Iterate on Your Solutions



Communicate Your Solutions at Event
Receive Feedback to Improve



Compete in Robot Game
Have Fun and Celebrate!

FIRST® LEGO® League Challenge Overview

CORE VALUES

Demonstrate *FIRST*® Core Values in everything you do. Your team will be evaluated during the Robot Game and the judging session.

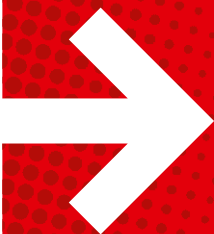

Your team will:

- Apply **teamwork** and **discovery** to explore the challenge.
- **Innovate** with new ideas about your robot and project.
- Show how your team and your solutions will have an **impact** and be **inclusive!**
- Celebrate by having **fun** in everything you do!

ROBOT DESIGN

Your team will prepare a short presentation on your robot design, programs, and strategy.

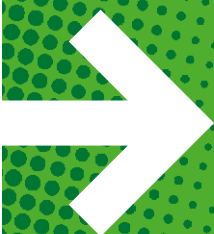

Your team will:

- **Identify** your mission strategy.
- **Design** your robot and programs and create an effective plan.
- **Create** your robot and coding solution.
- **Iterate**, test, and improve your robot and program.
- **Communicate** your robot design process and everyone's contributions.

ROBOT GAME

Your team will have three 2.5-minute matches to complete as many missions as possible.

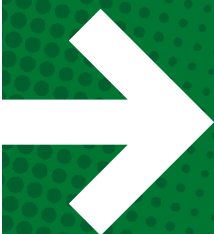

Your team will:

- Build the mission models and follow the field setup to put the models on the mat.
- Review the missions and rules.
- Design and build a robot.
- Explore building and coding skills while practicing with your robot on the mat.
- Compete at an event!

INNOVATION PROJECT

Your team will prepare a live, engaging presentation to explain the work you have done on your Innovation Project.



Your team will:

- **Identify** and research a problem to solve.
- **Design** a new solution or improve an existing one based on your selected idea, brainstorming, and plan.
- **Create** a model, drawing, or prototype.
- **Iterate** on your solution by sharing it with others and collecting feedback.
- **Communicate** your solution's impact.

Innovation Project

From the machines that move us to the electronics that connect us to the ways we power our cities and towns, energy is essential in our lives. Have you thought about where energy comes from? How it's generated? How it gets to you? How much you're using?



Explore your energy journey. How can you reimagine a better energy future? It starts here, with your critical thinking and innovation leading the way to tomorrow's energized world with *FIRST*[®] *ENERGIZE*SM presented by Qualcomm.

→ Identify a specific problem related to improving your energy journey.

An energy journey is where energy comes from and how it is distributed, stored, and used. The Project Sparks (see Sessions 1-4) explore problems related to different energy journeys. Your problem could come from a Project Spark, or it could be a different problem you want to solve.

→ Research your problem and solution ideas.

Explore energy sources and how energy is stored, distributed, and used in your community. Can you find ways to make part of your energy journey better? Can you improve one step to be more efficient, reliable, affordable, accessible, or sustainable? What solutions already exist? Are there any experts or users you could interview?

→ Design and create a solution that could improve your energy journey.

Use your research and explorations to either improve an existing solution used in your energy journey or design a new innovative solution. Can you make different energy technology choices? Make a drawing, model, or prototype of your solution.

→ Share your ideas, collect feedback, and iterate on your solution.

The more you iterate and develop your ideas, the more you will learn. What impact will your solution have on your community?

→ Communicate your solution with a live presentation at an event.

Prepare a creative and effective presentation that clearly explains your Innovation Project solution and its impact on others. Make sure your whole team is involved in sharing your progress.

Interested in taking your Innovation Project further? Learn more about implementation and entrepreneurship through the Global Innovation Awards.

FIRST
LEGO
LEARNER
GLOBAL INNOVATION AWARD

→ Check out the cartoon strip at the back of this guide!



Robot Design and Robot Game

This year's SUPERPOWEREDSM Robot Game is about collecting energy units from different sources around the mat and distributing them to where the energy will be consumed. Points are scored for releasing energy units from the models and for delivering energy units to target destinations.

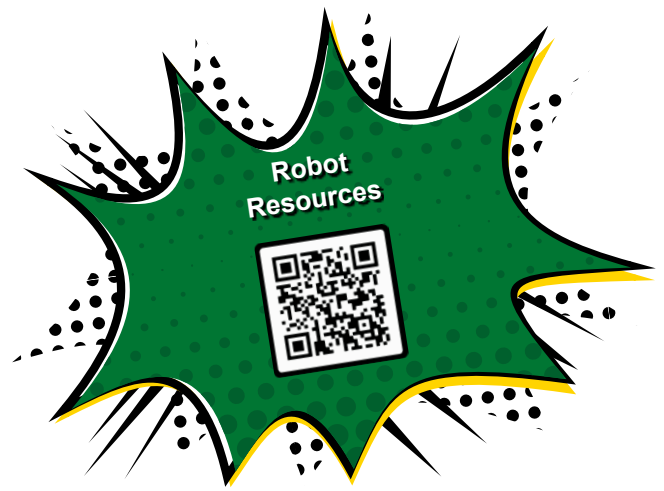

→ START

Design and create a robot that will complete missions in the Robot Game. Your innovative Robot Design, clear mission strategy, and functional programs are key in the *FIRST*[®] ENERGIZESM season presented by Qualcomm.

→ Build your mission models and identify your mission strategy.

Each mission and model also provide inspiration for possible solutions to your Innovation Project. You will find four different energy journeys on the mat. You can complete the missions in any order!

→ Design and create your autonomous robot and programs.

Create a plan for your robot design. Build a robot and its attachments using LEGO[®] Education SPIKE[™] Prime or any LEGO Education-compatible set. Code your robot to complete a series of missions autonomously in a 2.5-minute Robot Game to score points.

→ Test and iterate on your robot solution to complete missions.

Iterate on your robot design and programs with continual testing and improvements.

→ Communicate your Robot Design solution at judging.

Prepare a short presentation that clearly explains the process your team used to create your robot and programs and how they work. Make sure your whole team is involved.

→ Compete in Robot Game matches.

Your robot starts in a launch area, tries missions in an order of your team's choosing, and returns anywhere into home. You can modify your robot when it is in home before launching it again. Your team will play multiple matches, but only your highest score matters.



Team Roles

Here are sample roles your team can use during the sessions. Everyone on the team should experience each role throughout their *FIRST*® *LEGO*® League

Challenge experience. The goal is to build your team to be confident and capable in all aspects of *FIRST* *LEGO* League Challenge.

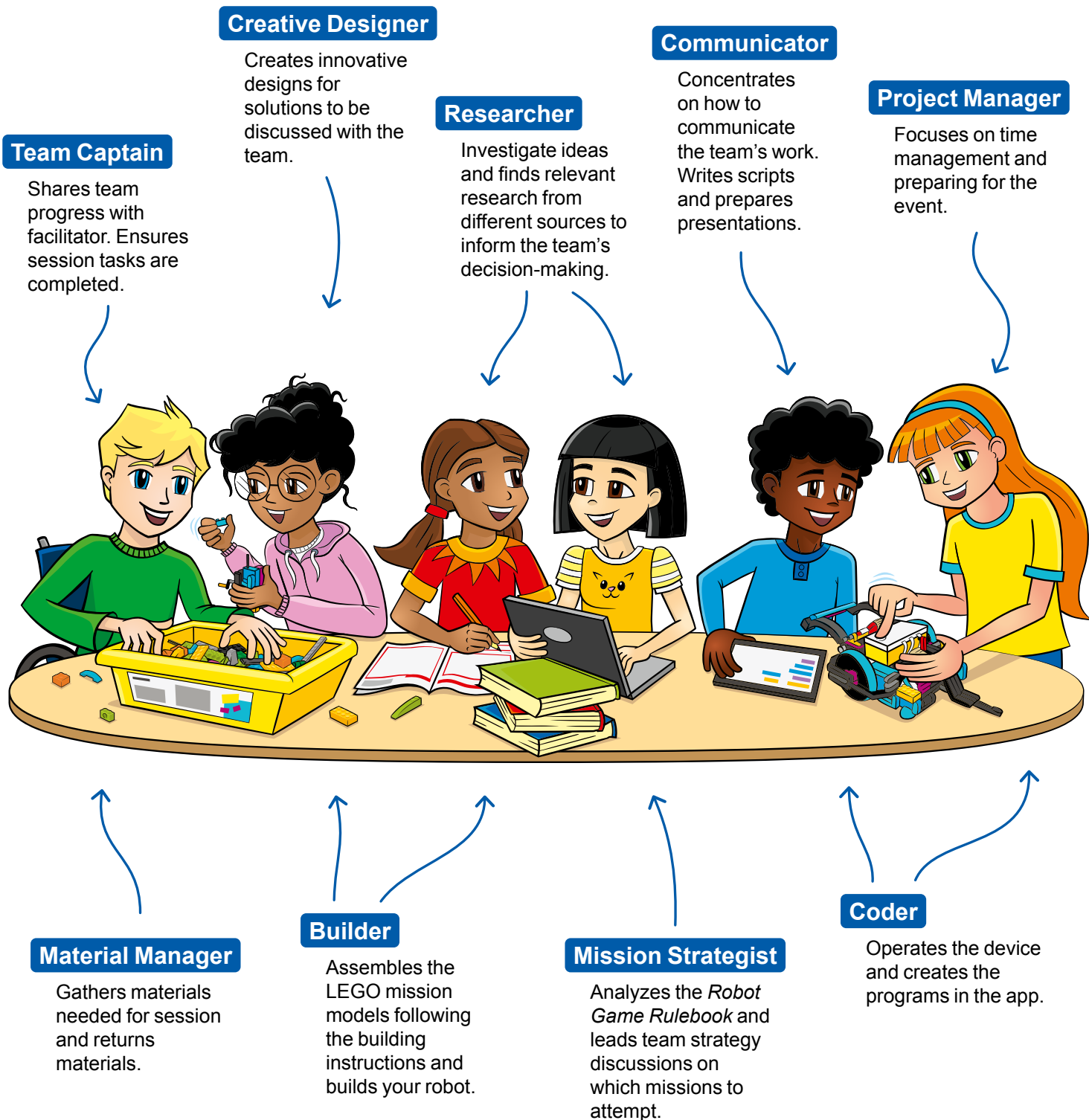

Energy Journeys



Energy Source

Energy Storage

Energy Consumption

White Energy Journey

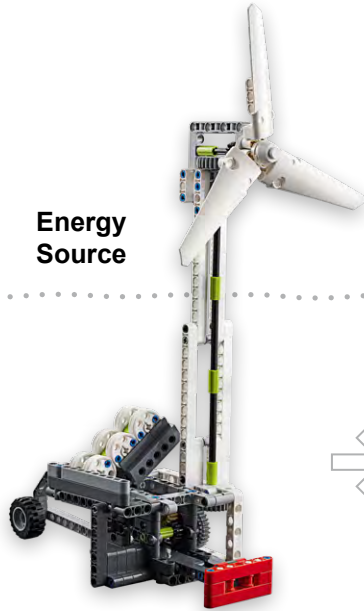
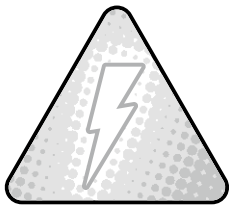

Blue Energy Journey

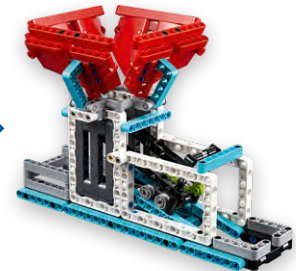
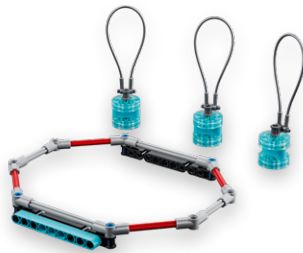
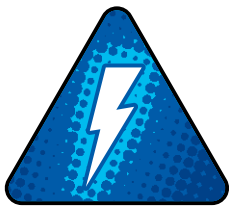

Yellow Energy Journey



Orange Energy Journey

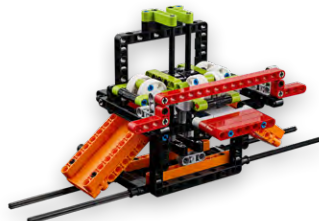
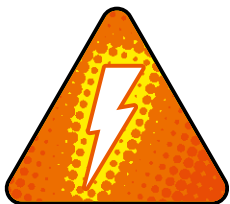

Look at the mat to find the different ways energy is distributed between its source, storage, and consumption.

→ Introduction (10-15 minutes)

- Watch the season videos and read pages 3-9 on how *FIRST*® LEGO® League Challenge works and the SUPERPOWEREDSM challenge.

→ Tasks (50-60 minutes)

- Open the SPIKE™ Prime app. Find your lesson.



Getting Started Activities: 1-6

- Identify the missions that could be solved with the coding skills learned in this lesson.
- Check out the *Robot Game Rulebook* for mission details.
- Try it out! See if you can use the skills you learned to complete a mission.

→ Reflection Questions

- How could stopping a motor help you solve a mission with your robot?
- What do you know about energy? What are resources that can help you learn more?



What are the four parts of *FIRST* LEGO League Challenge?

Our Notes:

The *Robot Game Rulebook* is a great resource to use throughout the sessions.



White Energy Journey

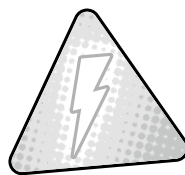

Project Spark

Renewable energy comes from natural sources that will never run out. Amazing new technologies are being developed to capture and store energy from these types of renewable sources.

Think about and research:

- Are renewable energy sources reliable?
- How can we store energy when the wind is not blowing or the sun is not shining?
- How do we make the use of renewable energy technologies more widespread?
- What is the impact of using these renewable technologies?

Our Ideas:

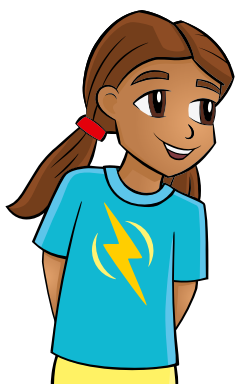

What work does a wind energy engineer do?

→ Tasks

(50-60 minutes)

- Read the Project Spark.
- Build the white energy journey models in Bags 4, 7, and 8 using Building Instruction Books 4, 7 and 8.
- Look over the white energy journey on page 9.
- Review the missions that relate to the models you built.
- Discuss how the mission models are linked to the Project Spark.
- Capture your ideas.

→ Share

(10-15 minutes)

- Get together at the mat.
- Place each model where it belongs. Refer to the Field Setup section in the *Robot Game Rulebook*.
- Show the robot skills you learned.
- Show how the models work and explain how they relate to the Project Spark.
- Discuss the reflection questions.
- Clean up your space.

→ Reflection Questions

- What Innovation Project ideas do the mission models spark?
- What are the pros and cons of the different parts of the **white** energy journey?



→ Introduction (10-15 minutes)

- Think about some goals you want to achieve. These can grow and change throughout your journey.
- Use the engineering design process and try out using team roles listed on page 8 in this session.

→ Tasks (50-60 minutes)

- Open the SPIKE™ Prime app. Find your lesson.



Competition Ready Unit: Training Camp 1: Driving Around

- Determine what coding and building skills you can apply in the Robot Game.
- Try it out! See if you can use the skills you learned to drive your robot to one of the mission models.

→ Reflection Questions

- How can you aim your robot toward a model?
- How did you use the engineering design process and team roles in this session?



My Personal Goals:

Our Notes:



Use these goal prompts for inspiration!

We will use Core Values to . . .

We want to experience . . .

We want our robot to . . .

We want our Innovation Project to . . .

Blue Energy Journey

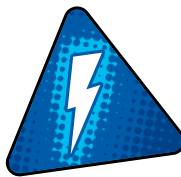

Project Spark

Hydroelectric stations can generate electricity using moving water. Water that passes through the turbines can be pumped back up to the reservoir at the top of the dam to be used again. This is a good way to use surplus energy that consumers are not using.

Think about and research:

- How could surplus energy from renewable sources be used in your community?
- How is energy used in industries and homes?
- How is water in the oceans used to capture energy?
- Could water be used to capture energy where you live?

Our Ideas:

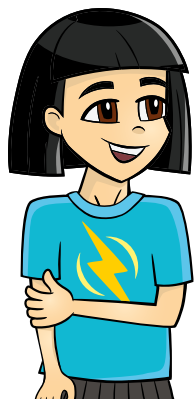

What skills do you need to be a hydroelectric specialist?

→ Tasks

(50-60 minutes)

- Explore the Project Spark.
- Build the blue energy journey models in Bags 11-13 using Building Instruction Books 11-13.
- Review the blue energy journey on page 9.
- Look over the missions that correspond to the models.
- Talk about how the mission models relate to the Project Spark.
- Capture your ideas.

→ Share

(10-15 minutes)

- Get together at the mat.
- Place each model where it belongs. Refer to the Field Setup section in the *Robot Game Rulebook*.
- Share the robot skills you learned.
- Show how the models work and explain their connections to the Project Spark.
- Chat about the reflection questions.
- Clean up your space.

→ Reflection Questions

- What are the positive and negative consequences of each segment of the **blue** energy journey?
- What are examples of renewable energy sources in your community?



→ Introduction (10-15 minutes)

- Locate the design tiles in Bag 15 for the energy storage display wall (in Bag 4), which you will use with the energy storage model later in this session.
- Create a team design with the design tiles to put on your display wall.
- Build your design on the panel using the design tiles.
- Be sure each person gets to contribute!



Our Team Design:

Our Notes:

→ Tasks (50-60 minutes)

- Open the SPIKE™ Prime app. Find your lesson.



Competition Ready Unit: Training Camp 2: Playing with Objects

- Reflect on the skills you learned that will be beneficial in completing missions.
- Try it out! See if you can code your robot to complete a mission.

→ Reflection Questions

- How can you drive your robot to collect the rechargeable battery?
- What objects does your robot need to avoid?

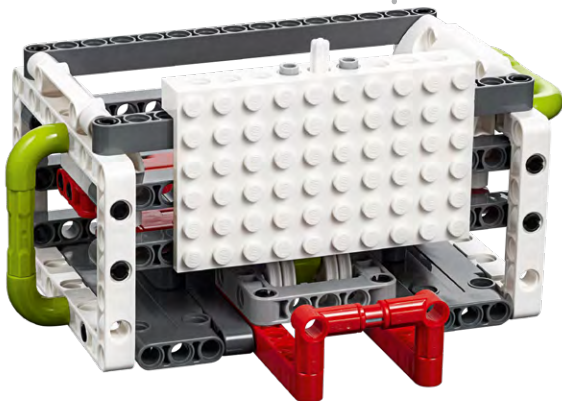

Yellow Energy Journey

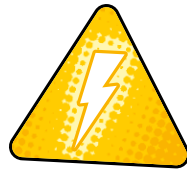

Project Spark

Providing energy when and where it is needed at an affordable cost is a massive challenge. We have become reliant on nonrenewable energy sources because they are convenient and often cost less.

Think about and research:

- How widespread is the use of nonrenewable resources?
- Why is it difficult to stop using nonrenewable energy?
- What solutions combine the use of renewable and nonrenewable energy sources?
- What are the impacts of using nonrenewable energy sources?
- What carbon capture technologies are being developed?

Our Ideas:

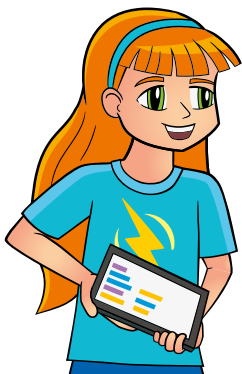

How does a substation technician help with energy distribution?

→ Tasks

(50-60 minutes)

- Look over the Project Spark.
- Build the yellow energy journey models in Bags 2, 3, and 6 using Building Instruction Books 2, 3, and 6.
- Review the yellow energy journey on page 9.
- Identify the missions that relate to the models you built.
- Discuss how the Project Spark and models are linked.
- Capture your ideas.

→ Share

(10-15 minutes)

- Get together at the mat.
- Place each model where it belongs.
- Share how the models work and the robot skills you learned.
- Demonstrate the models' functions and how they connect to the Project Spark.
- Talk about the reflection questions.
- Clean up your space.

→ Reflection Questions

- What are the positive and negative impacts of the different parts of the **yellow** energy journey?
- What are examples of nonrenewable energy sources in your community?



→ Introduction (10-15 minutes)

- Think about how you have used the Core Value of **discovery** in your team's journey so far.
- Record examples of how your team has learned new skills and ideas.

→ Tasks (50-60 minutes)

- Open the SPIKE™ Prime app. Find your lesson.



Competition Ready Unit: Training Camp 3: Reacting to Lines

- Determine what building and coding skills will help you in the Robot Game.
- Try it out! See if you can use the skills you learned to complete another mission.

→ Reflection Questions

- How did testing and debugging your program help make your robot more accurate?
- Can your robot follow the line from the left launch area to the energy storage model?

Discovery: We explore new skills and ideas.

Our Notes:

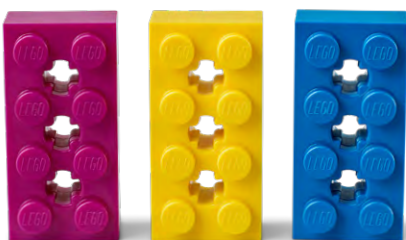

Orange Energy Journey

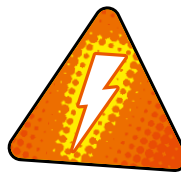

Project Spark

Energy can come from many different sources, and is used to generate electricity. This energy is transferred into a network grid that distributes electricity to energy consumers.

Think about and research:

- What are smart grids? How do they supply electricity to consumers?
- How could we alter the demand for electricity so that consumers use it when the electricity is abundant?
- How could energy be stored in your community so it is available when you need it?
- How do rechargeable batteries work? Why is this better than using disposable batteries?

Our Ideas:

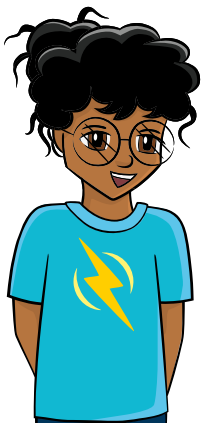

How could a sustainability team help reduce energy consumed in a factory?

→ Tasks

(50-60 minutes)

- Read the Project Spark.
- Build the orange energy journey models in Bags 5, 9, and 10 using Building Instruction Books 5, 9, and 10.
- Look over the orange energy journey on page 9.
- Identify the missions that relate to the models you built.
- Discuss how the Project Spark and models are linked.
- Capture your ideas.

→ Share

(10-15 minutes)

- Get together at the mat.
- Put each model where it belongs.
- Show how the models operate and their connection to the Project Spark.
- Show the robot skills you have learned.
- Discuss the reflection questions.
- Clean up your space.

→ Reflection Questions

- What are some long-term environmental impacts of **orange** energy journey sources?
- How is energy stored and distributed in your community?

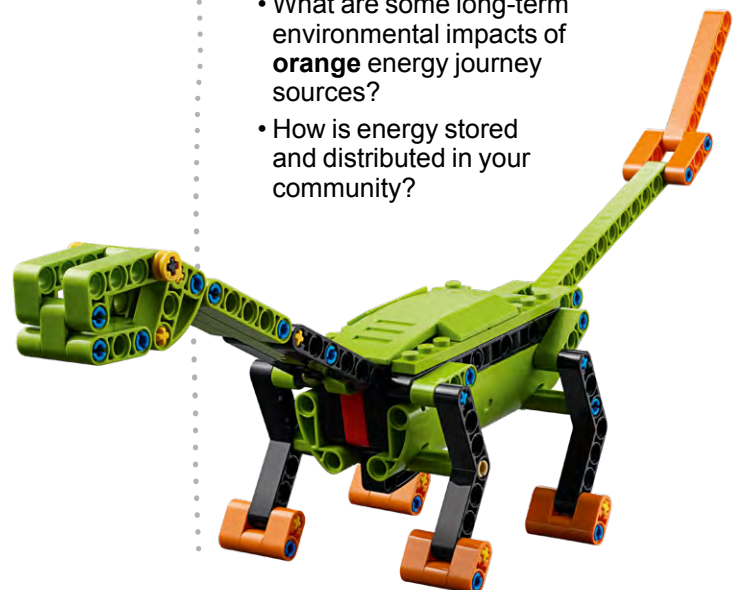

→ Introduction (10-15 minutes)

- Think about **teamwork** and your team.
- Record examples of how your team has learned to work together.

→ Tasks (50-60 minutes)

- Open the SPIKE™ Prime app. Find your lesson.



Competition Ready Unit: Guided Mission

- Read over the guided mission.
- Have fun practicing this guided mission until it works perfectly!

→ Reflection Questions

- What does the guided mission show you about *Coopertition*®?
- Can you change the program so that the mission works when you start the robot from the opposite launch area?

Teamwork: We are stronger when we work together.

Guided Mission: Mission 5 Smart Grid

To help you learn about navigating and interacting with a model, complete this guided mission.

New smart grid technology uses data to distribute electricity to the consumer where and when it is needed.

In the app, download the program that solves this mission. Start your robot in the correct position in the left launch area. Run your robot and watch it complete the mission and score the points.

Like all the mission models, Mission 5 Smart Grid might inspire you to think of a solution for your Innovation Project.

Think about how to incorporate the Smart Grid mission into your mission strategy.
Apply your new line-following skill to a different mission model.

Investigate Ideas

Research Findings:

→ Tasks

(50-60 minutes)

- Revisit page 9 and review the Project Sparks.
- Think about the great solutions you have come up with in the previous sessions.
- Research the Innovation Project and different problems you have identified.
- Use this page to capture your research.
- Identify the problem your team will solve and record your problem statement.

→ Share

(10-15 minutes)

- Get together at the mat.
- Show how your robot scores points on the guided mission.
- Discuss the problem your team has identified and think about next steps.
- Discuss the reflection questions.
- Clean up your space.

→ Reflection Questions

- What energy problem did you decide to solve?
- Is there an expert or end user you can talk to about the problem?

Problem Statement:

→ Introduction (10-15 minutes)

- Locate Bag 14 that contains the LEGO® bricks that you will use to create your Innovation Project model.
- Work as a team to build your initial solution idea for your identified problem.

→ Tasks (50-60 minutes)

- Watch the “Robot Game Missions” video.
- Start to think about your mission strategy.
- Design an effective plan.
- Discuss which missions your team will attempt first.
- Complete Pseudocode on page 22.
- Think about how the program will make your robot act.
- Revisit the earlier lessons or do the optional lesson listed here.



Competition Ready Unit: Assembling an Advanced Driving Base

→ Reflection Questions

- How could you use line following on the horizontal line at the top of the mat to help you navigate to the solar farm?
- How did you use the engineering design process to create your mission strategy?



Innovation Project Model Design:

Strategy:

Pseudocode is a written description of the steps for your planned robot program.

Identify Solutions

PROBLEM AND SOLUTION ANALYSIS

Record important information here.

→ Tasks

(50-60 minutes)

- Research the problem you chose and any existing solutions.
- Generate solution ideas. Make a plan for how you will develop your solution. Use page 23, Innovation Project Planning, as a tool.
- Be sure to use a variety of sources and keep track of them on the Innovation Project Planning page.
- Select your project's final solution as a team.

→ Share

(10-15 minutes)

- Get together at the mat.
- Review your Pseudocode page. Make changes to the page if necessary.
- Explain what you discovered in your research. Discuss any solution ideas.
- Discuss the reflection questions.
- Clean up your space.

→ Reflection Questions

- What types of improvements do existing solutions need?
- What are your brand-new ideas to solve the problem?

Guiding Questions:

- What questions are you trying to answer?
- What information are you looking for?
- Can you use different types of sources such as credible Internet websites, books, and experts?
- Does your source have information relevant to your project?
- Is this a good and accurate source of information?
- How do your Innovation Project plans connect with the Innovation Project rubric?



Pseudocode

Mission Name:

Mission Number:

CODING STEPS

Write out the moves the robot should make to complete the mission.

Move 1

Move 6

Move 2

Move 7

Move 3

Move 8

Move 4

Move 9

Move 5

Move 10

ROBOT PATH DIAGRAM

Draw the route your robot will take to complete the mission.

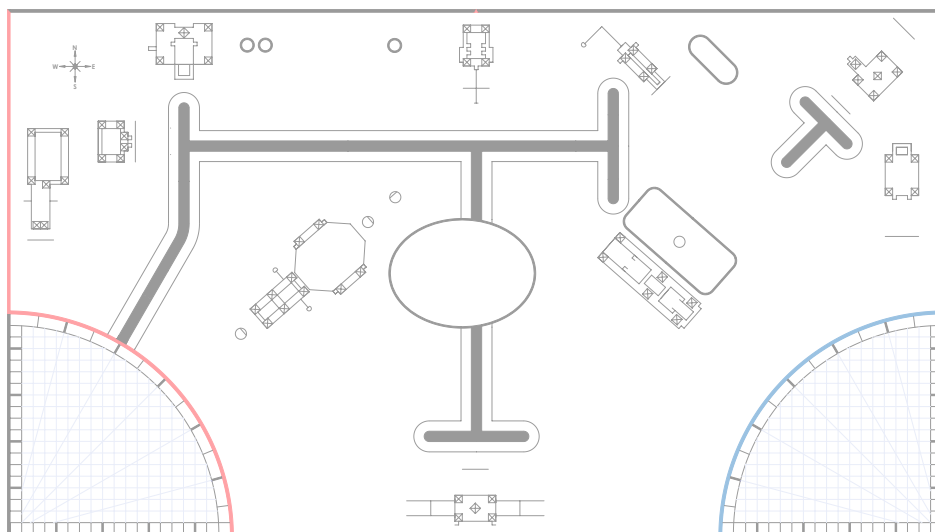

Go to the app and start a new project. Explore which coding blocks will move your robot the same way as your planned coding steps would move it.

Complete this page in Session 6.

Innovation Project Planning

PROCESS

Describe the process you followed to develop your innovative solution.

SOURCES

Write down where you got your information. Include details such as the title, author, and website.

1.

2.

3.

Complete this page in Session 6.

→ Introduction (10-15 minutes)

- Think about **Gracious Professionalism®**.
- Write ways your team will demonstrate this in everything you do.
- Look over page 6 in the *Robot Game Rulebook* to see how *Gracious Professionalism* is evaluated during the tournament.

→ Tasks (50-60 minutes)

- Continue to develop your robot and its attachments to complete missions in the Robot Game.
- You can improve the existing robot used in the previous sessions or create a new design.
- Create a program for each new mission you attempt. You could combine mission solutions into one program.
- Test and improve your robot and its programs.
- Revisit previous lessons to develop your coding skills or work on solving the missions.

→ Reflection Questions

- Can you follow how the program on your device is making your robot move?
- How can you iterate and improve on the existing robot design used in previous sessions?

Gracious Professionalism: We show high-quality work, highlight the value of others, and respect individuals and the community.

Robot Design:

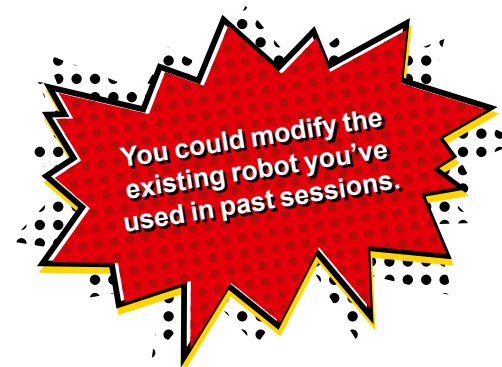

Create Solutions

PROJECT DRAWING

PROJECT DESCRIPTION

→ Tasks

(50-60 minutes)

- Develop and create your Innovation Project solution.
- Sketch your solution. Label the parts and how it will work.
- Describe your solution and explain how it solves the problem.
- Create a prototype, model, or drawing of your solution.
- Document the process you use to develop your solution on page 23, Innovation Project Planning.

→ Share

(10-15 minutes)

- Get together at the mat.
- Show any missions you are working on or have completed.
- Discuss your research and your Innovation Project solution.
- Discuss the reflection questions.
- Clean up your space.

→ Reflection Questions

- Can you describe your innovative solution in under five minutes?
- How does your solution address your identified problem?

→ Introduction (10-15 minutes)

- Reflect on **Coopertition**[®].
- Note ways your team will demonstrate this at an event.

→ Tasks (50-60 minutes)

- Decide which mission to attempt next.
- Think about your mission strategy and plan.
- Build any attachments you need to complete missions.
- Iterate and refine your program so your robot completes the mission reliably.
- Be sure to document your design process and testing for each mission!

→ Reflection Questions

- How has your team used Core Values to develop your robot solution?
- In what order will you run the missions in the Robot Game?



Coopertition: We show that learning is more important than winning. We help others even as we compete.

Design Process:

Guiding Questions:

- Describe the attachments you built.
- Explain your different programs and what the robot will do.
- How did you test your programs and attachments?
- What changes did you make to your robot and programs?
- How does your robot plan connect with the Robot Design rubric?

Continue Creating

Plan to Share:

Our Improvements:

→ Tasks

(50-60 minutes)

- Make a plan to share about your solution with others!
- Evaluate your present solution.
- Iterate and improve to make it better based on feedback.
- Determine if you can do any testing of your solution.
- Use the elements from Bag 14 to build a model that represents your Innovation Project solution.

→ Share

(10-15 minutes)

- Get together at the mat.
- Show any missions you are working on or have completed.
- Discuss how you will share your solution and project plan with others.
- Discuss the reflection questions.
- Clean up your space.

→ Reflection Questions

- How can you realistically implement your Innovation Project solution?
- Could your Innovation Project solution be manufactured? What would it cost?

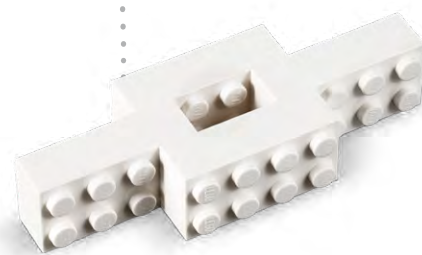
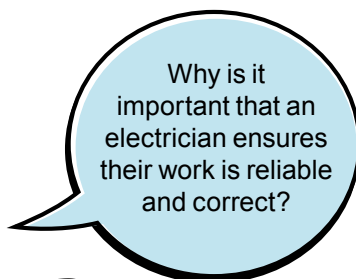

→ Introduction (10-15 minutes)

- Think about **innovation** and your team.
- Record examples of how your team has been creative and solved problems.

→ Tasks (100-120 minutes)

- Code your robot to complete the Mission 1 Innovation Project using the model you created.
- Think about your mission strategy on the mat and the missions you will solve.
- Continue to create a solution for each mission as time allows.
- Test, iterate, and improve your robot and Innovation Project solutions. Be sure to document all this.

→ Share (10-15 minutes)

- Get together at the mat.
- Show the work completed on the Innovation Project and Robot Game.
- Look over the Core Values rubric. Talk about how you will demonstrate Core Values at the event and judging session.
- Clean up your space.

→ Reflection Questions

- What features on your robot show good mechanics?
- What changes have you made to your Innovation Project solution based on feedback from others?
- What progress have you made on the goals set in Session 2?

Innovation: We use creativity and persistence to solve problems.

Iterations and Improvements:

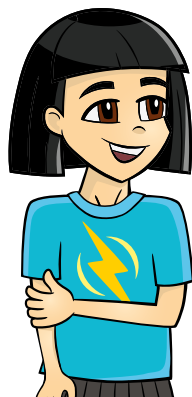

How does a solar panel installer use teamwork on the job?

Session 10

Iterate Solutions

Impact: We apply what we learn to improve our world.

Presentation Script:

→ Introduction (10-15 minutes)

- Think about **impact** and your team.
- Record examples of how your team has had a positive influence on you and others.

→ Tasks (100-120 minutes)

- Plan out your project presentation. Refer to the Innovation Project rubric for what to cover.
- Write out your Innovation Project presentation script.
- Make any props or displays that you need. Be engaging and creative!
- Continue to create, test, and iterate on your robot solution.
- Practice a 2.5-minute Robot Game with all your completed missions.

→ Share (10-15 minutes)

- Get together at the mat.
- Share the project presentation work completed.
- Share what missions you have completed.
- Discuss how everyone will be involved in the presentation.
- Discuss the reflection questions and clean up your space.

→ Reflection Questions

- How did you decide which missions to attempt?
- How can your Innovation Project solution help your community?
- What skills have you developed throughout your SUPERPOWEREDSM experience?

How will your Innovation Project solution have an impact on others?



Session 11

Presentation Planning

→ Introduction (10-15 minutes)

- Think about **inclusion** and your team.
- Record examples of how your team makes sure everyone is respected and their voices are heard.

→ Tasks (100-120 minutes)

- Continue working on your Innovation Project presentation.
- Plan and write out your Robot Design presentation. Refer to the Robot Design Rubric for what to cover.
- Make sure everyone can communicate about your design process and programs.
- Determine what each person on the team will say.
- Practice your full presentation.

→ Share (10-15 minutes)

- Get together at the mat.
- Discuss the presentation and each person's role.
- Run a practice 2.5-minute match and explain what missions were done.
- Discuss the reflection questions.
- Decide what else needs to be done and clean up your space.

→ Reflection Questions

- What will you do if one mission does not work?
- How is everyone involved in the presentation?
- How has **FIRST® LEGO®** League impacted you?

Inclusion: We respect each other and embrace our differences.

Presentation Script:

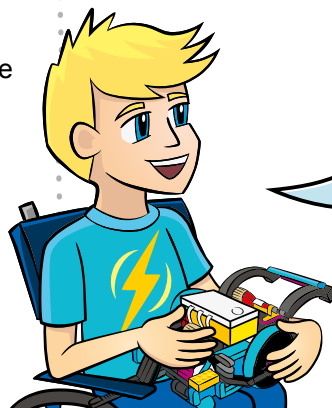

Review the judging session flowchart to see how you will present your Robot Design and Innovation Project.

Session 12

Communicate Solutions

Fun: We enjoy and celebrate what we do!

Presentation Feedback:

→ Introduction (10 minutes)

- Reflect on how your team has had **fun**.
- Record examples of how your team has had fun throughout this experience.
- Think about your team's goals. Did you meet them?

→ Tasks (100 minutes)

- Rehearse your full presentation communicating your robot and Innovation Project solutions.
- Demonstrate Core Values when you present!
- Have practice 2.5-minute Robot Game matches.
- Review pages 32-33, Prepare for Your Event.

→ Share (10 minutes)

- Review the Core Values, Innovation Project, and Robot Game Rubrics.
- Provide helpful feedback after the presentation to each other based on the rubrics.
- Discuss the reflection questions.
- Clean up your space.

→ Reflection Questions

- What is your plan for having any LEGO® attachments built ready for the Robot Game?
- Is everyone ready to speak clearly, smile, and have fun?
- What has your team accomplished?



Prepare for Your Event

Make a list of what you need to bring to your event. Read over the event day schedule.

Reflect on the Core Values your team has used.

Can you provide examples of your team using Core Values and demonstrating *Gracious Professionalism*®?

Think about all the work you've done on the Innovation Project.

How will you present the problem you researched?
How will you explain the process used to create and iterate on your Innovation Project solutions?

Talk about the programs you've created for your robot.

How do your programs match your mission strategy?
How do your programs make your robot act?

Think about your Robot Design.

How will you explain the design process and plan used to create and test your robot?

Think about your team.

How will each person on the team participate in the live presentation and show their knowledge?

What to Expect at Your Event

- Your team should have fun and show team spirit and enthusiasm at the event. Be sure to show Core Values into everything you do.
- Your whole team will meet with the judges in a single judging session to share your team's journey throughout the season. Think about what you have achieved and what challenges you have faced and overcome.

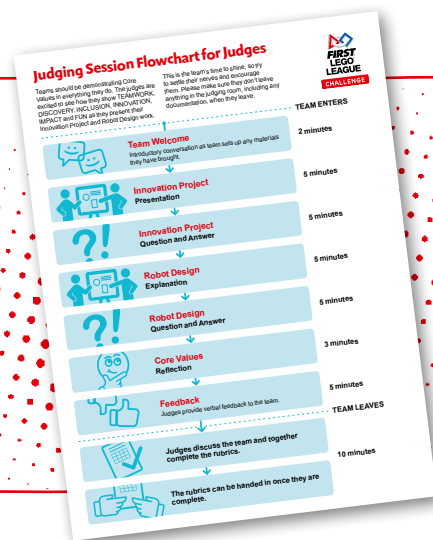

We will describe our Robot Design and all its different parts.

We will present our Innovation Project!

We will reflect on how our team showed Core Values.

We will explain our different programs and how they make our robot act.

We will share about our team's journey.

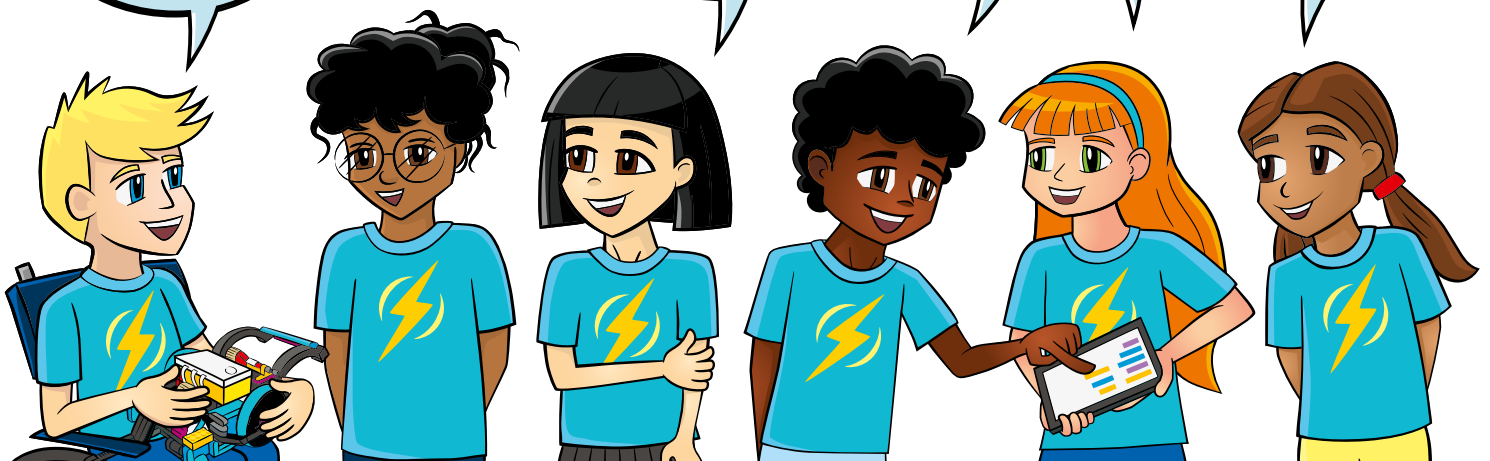

FIRST® LEGO® League is evaluated equally in four areas: Core Values, Innovation Project, Robot Design, and Robot Game. The judges and referees use the rubrics and Robot Game scoresheets to make this evaluation.

Make sure you are familiar with the rubrics. It is your team's job to explain everything to the judges during the session.

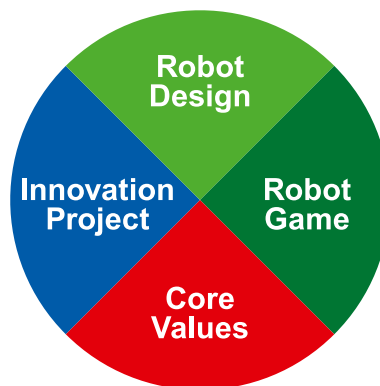

Team Rubrics

Class Pack Rubric



FIRST LEGO League teams express their Core Values through *Gracious Professionalism*®. This will be evaluated by referees for each team at every Robot Game match.

During the Robot Game, only some team members can be at the table during the 2.5-minute match. You can tag in other team members for different missions.

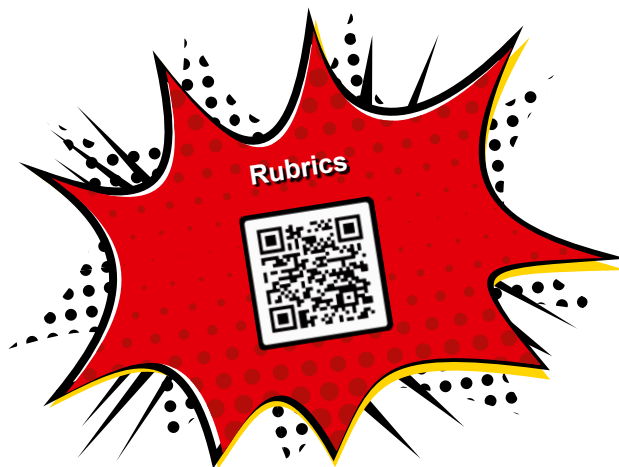

Career Connections



Wind Energy Engineer

A wind energy engineer designs wind turbines and wind farms and then creates and tests them in the field.

Links to Session 1



Solar Panel Installer

A solar panel installer installs solar panels according to directions and safety requirements.

Links to Session 9



Hydroelectric Specialist

A hydroelectric specialist installs, maintains, and operates hydroelectric power systems and equipment.

Links to Session 2



Exploration

(Recommend completing after Session 4 or 9)

Look at the careers on these pages. Choose a job role, research it, and answer the questions.

- Explain the job. What are some of this job's daily tasks?
- What education or training is required?
- What is this job's yearly salary?
- What companies could people in this job work for?

Fields of Study

- Renewable energy
- Energy end use and efficiency
- Energy storage and grid modernization
- Energy policy and economics
- Energy environmental impact
- Fossil energy



Substation Technician

A substation technician operates and maintains electrical substations that distribute energy from sources to consumers.

Links to Session 3



Electrician

An electrician ensures homes are wired correctly so that people can use electricity to power their electronics and lights.

Links to Session 8



Sustainability Lead

The sustainability lead looks for ways to use renewable energies and less waste to create products in factories.

Links to Session 4



Reflection

(Recommend completing after Session 12)

Look at the careers on these pages. Think about these jobs and what interests you.

- What skills are needed in these jobs?
- What interests you about these jobs?
- Can you think of other jobs that relate to energy?
- Can you explore one of these careers for more information?



Energy is an important part of our lives. Our *FIRST*® LEGO® League heroes know the choices we make impact our world.

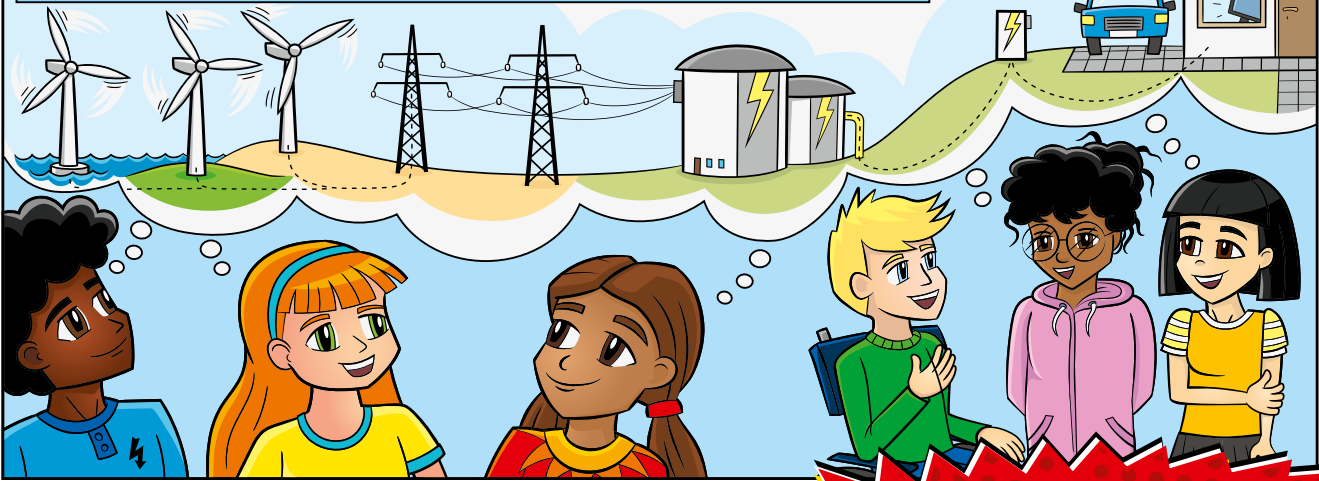

Let's start with our community – they need our help!

How do we get energy?

Your challenge is to improve the energy journey in YOUR community!

How do we distribute and store it?

How do we consume it?



Hmm... let's identify a problem and design a solution!

We'll need more heroes.

